

CLUSTERINGS OF EXTREME RAINFALLS AND EVOLUTION OF FLUVIAL SYSTEMS IN THE HOLOCENE

Leszek Starkel

*Department of Geomorphology and Hydrology, Institute of Geography, Polish Academy of Sciences,
31-018 Kraków, ul. Św. Jana 22, e-mail: starkel@zg.pan.krakow.pl*

Abstract

The term extreme rainfall refers to an event during which the thresholds of various hydrological and geomorphic processes are exceeded. The frequency of extremes varies in different climatic zones and in time.

The clustering of extreme events happens when the extremes are repeated every 2–3 years, every year or even several times a year. Such clusterings disturb the equilibrium of slope and river channel systems and are separated by periods of stability and recovery. The occurrences of clusters are exemplified by present – day processes, historical records and geological records. On this base a model of phases with frequent and rare clusterings during the Holocene was constructed.

sq

Key words: fluvial system, clustering of extremes, Holocene

INTRODUCTION

The extreme rainfall refers to an event during which the thresholds of various processes like overland flow and slope wash, different mass movements or bankfull discharge and overbank deposition are exceeded. This leads to the disturbance of equilibrium and transformation of slope or/and river channel systems.

The type and scale of the transformation depends on various conditions in precipitation, runoff and water storage, connected also with differences in relief energy, lithology of substratum and vegetation cover (cf. Starkel 1976, 1998). There is a distinct difference in effectiveness between local heavy downpours with rainfall intensity reaching several mm/min, continuous rainfall with its totals exceeding several hundreds of mm in 2–5 days, rainy season with high groundwater storage and finally rapid snowmelt (Starkel 2002). Especially intensive processes are connected with the superposition of two different events like continuous rain followed by downpour or rapid snowmelt combined with heavy rain.

Type and frequency of extremes differ in various climatic zones. In the subarctic and boreal zone annually occurring snowmelt floods are the most common (Lvovitch 1979). In the temperate zone various types of extremes may appear: in addition to heavy downpours continuous rains and other are present. Their frequency also fluctuates, although usually there are not more than ten events in one century. In arid zone the rare heavy downpours are the most characteristic phenomena. In the humid tropics the frequency of heavy rainfalls, disturbing the equilibrium of natural systems, may differ from several in one century (Starkel, Basu 2000) to more than one every summer (Starkel *et al.* 2002).

CLUSTERING OF EXTREMES AS TRIGGERS OF DISTURBANCE OF NATURAL SYSTEMS

The clustering of extreme events occurs when the extremes are repeated every 2–3 years, every year or even several times in one year. Clusterings are separated by periods of stability and recovery of the disturbed natural systems. Those periods are at least several times longer than the clustering.

Clustering itself means that the time for relaxation is missed and therefore disturbance of equilibrium of natural system may easily occur and a new equilibrium may be formed (Fig. 1). Such conditions can be observed in the records of last centuries in various parts of temperate and Mediterranean Europe as well as in monsoonal Asia, and arid SW-USA.

In case of Cherrapunji (Starkel *et al.* 2002) several extreme rainfalls are recorded every year and there is no time for relaxation. In such circumstances a new equilibrium of the system has been formed. Similar annual floods are recorded in the Brahmaputra river valley, where every year part of the catchment is suffered by heavy rainfalls (Goswami 1998).

CLUSTERS TRANSFORMING THE FLUVIAL SYSTEMS

The classical example is described from the Gila River in Arizona (Burkham 1972) where the flood clustering between 1905 and 1920 caused a change from the channel to braided form and even next 20 years were not enough for return to its previous shape.

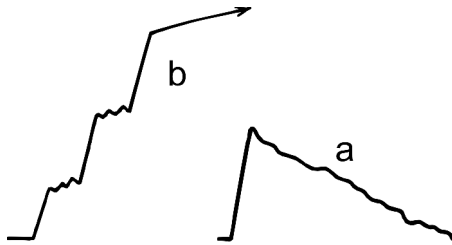

Fig. 1. Single extreme event with relaxation phase (a) and clustering of extremes leading to new equilibrium (b).

In the Polish Carpathians such clusters are very common (Fig. 2). The widening of river channels and distinct transformation of slopes were observed after a sequence of continuous rains in 1958-60 in Beskid Żywiecki (Ziętara 1968). The turn to incision of the Ropa river channel followed after floods in 1970-74 (Soja 1977). Various types of heavy rainfalls between 1997 and 2001 reactivated many Carpathians landslides (Rączkowski, Mrozek 2002). In the Dunajec catchment appeared an incision and widening of channels in many creeks after several local downpours superimposed on continuous rain in July 1997 (Froehlich 1998). Three local downpours in 1995 and 1996 after 60 years of stability caused jointly intensive slope wash, gully erosion and alluviation over the loess plateau north of Cracow (Starkel ed. 1997).

In the Tyne basin in northern England the clusters of floods in the late 18th, late 19th century and in 1950s and 1960s triggered the incision of river channel and set off the formation of next alluvial fills (Rumsby, Macklin 1996). Clusters of floods in the last centuries are recorded from various European rivers (cf. Probst 1989), among them the Span-

ish ones (Benito *et al.* 1996, Lopez-Aviles *et al.* 1998), the Garonne (Decamps *et al.* 1989), and the upper Vistula (Starkel 1998, 2002).

At the margin of Bhutanese Himalaya in 1993, 1996 and 1998, 3-4 heavy continuous rains with rain totals of 800-1500 mm were recorded. Each of those events caused an expansion of landslides and debris flows as well as an extension of aggradational braided channel pattern in the mountain foreland as recorded on satellite pictures (Starkel, Sarkar 2002). As a result an extensive piedmont plain is being formed and its roots enter upstream into the mountains.

CLUSTERING IN HOLOCENE RECORDS

Clustering of heavy rainfalls and floods are commonly documented in historical records especially from the Little Ice Age (Benito *et al.* 1996, Camuffo, Enzi 1994, Pavese *et al.* 1992, Brazdil *et al.* 1999, Starkel 2001). Very distinct clusterings were recorded in 1520-60s at the beginning of the Little Ice Age. Similar clusterings of heavy downpours reflected in debris flow frequency were found in early 19th century in the Tatra Mts (Kotarba 1995).

Late Mediaeval clusters from the 12th-15th centuries are described from Mediterranean rivers of Italy (Camuffo and Enzi 1994) and Spain (Benito *et al.* 1998) representing a transitional phase from the Mediaeval warming to the Little Ice Age.

The clusters can also be recognised in geological records of alluvial fills. Among them there are the resubfossil oak trunks found in river valleys of Southern Germany (Becker 1982, Leuschner *et al.* 2000) and Southern Poland (Krapiec 1992, 1998, Starkel *et al.* 1996). Especially distinct are the oak clusters from the Kraków-Kujawy site in the Vistula val-

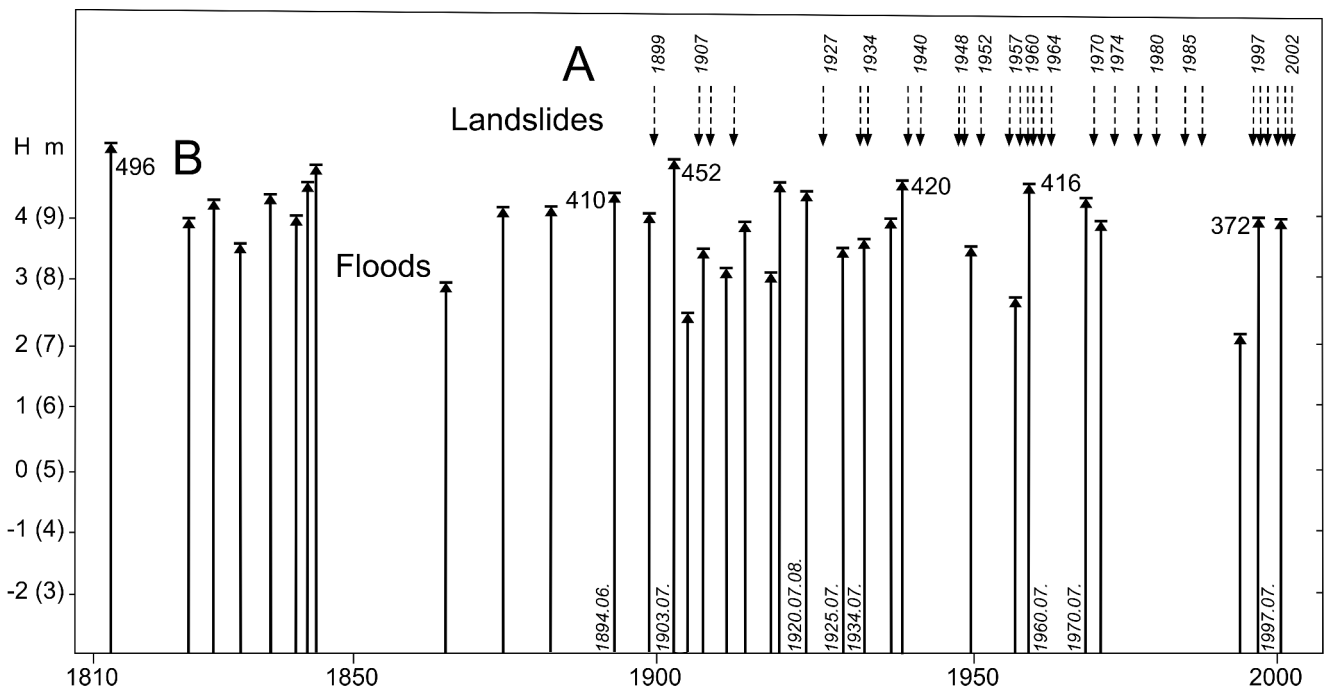

Fig. 2. Distinct clusterings of floods (B) in the Vistula valley in Cracow in 19-20-th century (based on Bielański 1984 – after Starkel 2002) and landslides (A) in the Carpathians since 1890s (after Rączkowski, Mrozek 2002). On vertical scale the water level records in meters used at present and in 19-th century (in brackets).

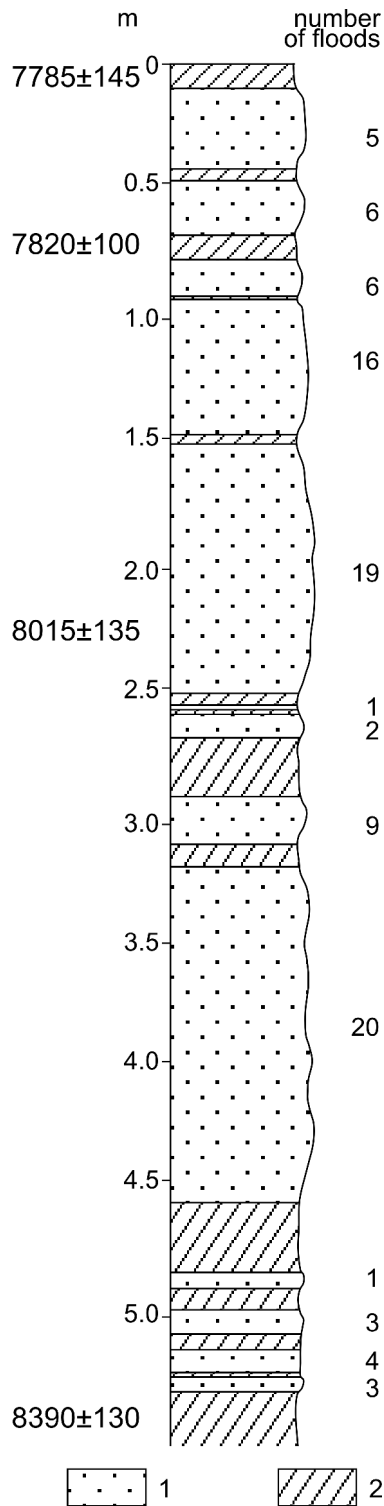

Fig. 3. Alluvial fan sequence at Podgrodzie presenting distinct clusterings of heavy rains and deposition between 7785 and 8390 ^{14}C yrs BP (after Starkel *et al.* 1996, Czyżowska 1997). 1 – clusterings of sandy and silty layers; 2 – organic peaty horizons.

ley dated at 450–480, 500–520, 900–920, 960–970 and 1060–1120 AD (cf. Starkel 2003).

In a similar way in arid zone the long records of cataclysmic floods enabled to estimate their frequency per century and finally identify the clustering phases (Enzel *et al.* 1996, Frumkin *et al.* 1998).

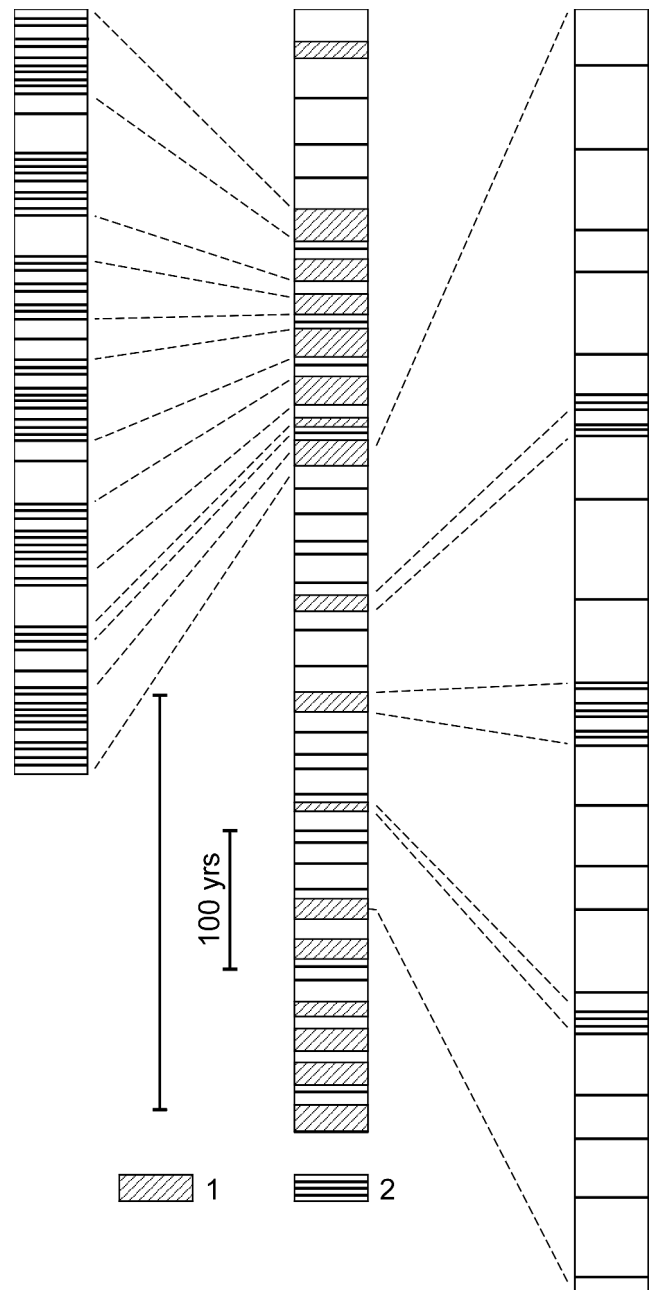

Fig. 4. Hierarchic model: phase-cluster-event. In the middle: alternate phases with various frequency of events and clusterings. On the left: enlarged wetter phase with many clusters. On the right: drier phase with lower frequency of events. 1 – clusterings; 2 – events.

Taking the Little Ice Age as the example similar clusters in the records representing similar alternating wetter and cooler phases of the Holocene were expected. Such records were indeed found in deposits from the oldest pre-Neolithic phase dated at 8.5–8.0 kyr ^{14}C BP, visible in various parts of the world due to coincidence of decline in solar activity and high volcanic activity (Bryson, Bryson 1998, Starkel 1999a).

The alluvial fan of small tributary of the Wisłoka river at the margin of the Polish Carpathians exposed 5.2 m of proluvial sediments is dated between 8390±130 and 7785±145 ^{14}C BP (Niedziałkowska *et al.* 1977, Starkel *et al.* 1996, Czyżowska 1997). The sequence contains 14 peaty-muddy lay-

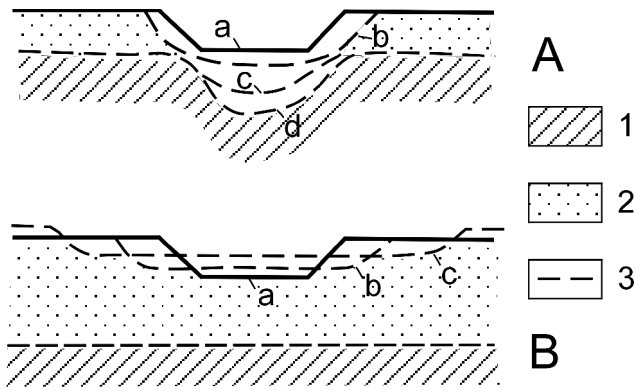

Fig. 5. Effects of cluster on channel incision (A) or aggradation (B). 1 – bedrock; 2 – alluvia; 3 – phases of evolution (a–d).

ers, each from several to 28 cm thick, alternating with 13 sandy-silty beds in which detailed granulometric and textural analysis helped to distinguish more than 100 layers representing 95 events. Each “bed” between two organic layers includes usually 3–20 events that together can be interpreted as a clustering (Fig. 3).

CONCLUSIONS

The analysis of present-day clusterings of extreme rainfalls and their hydrological, geomorphological and sedimentological effects as well as the examination of historic flood records (especially from the Little Ice Age) and geological records from various parts of the Holocene helped to con-

struct a hierarchic model of relationship between events, clusterings of events and climatic phase of the Holocene (Fig. 4). Its preliminary version was presented a few years ago (Starkel 1999b).

The Holocene can be divided into a sequence of wetter and cooler phases separated by relatively drier ones. The wetter phases are characterized by higher frequency of extreme events and coincide with advances of alpine glaciers, rises of lake levels *etc.* (Magny 1993, Patzelt 1977, Starkel 2003). These phases seem to be related to the declines in the solar activity, rises of residual $\Delta^{14}C$ (Stuiver *et al.* 1991, Bond *et al.* 1997) as well to increased frequency of volcanic eruptions (Bryson, Bryson 1998).

The wetter phases are commenced by the clusterings of heavy rainfalls, which are longer and more frequent than during alternating “drier” phases (Fig. 4). It is not excluded that these clusters are connected with the variations of ENSO, with volcanic activity and other factors.

Clusters of extreme rainfalls are reflected in the fluvial environment. These are responsible for a change towards channel incision or to aggradation (Fig. 5). Also, as it was suggested by Rumsby and Macklin (1996) the clustering initiate new cut and fill in the valley floor (Fig. 6). This means that the cut- and fill system recognised in the Vistula catchment long time ago (Starkel 1983) may not only reflect the sequence of wetter and drier phases, but also clusterings of shorter duration. It is also not excluded that after the extensive deforestation of European catchments due to accelerated runoff and sediment load the clusters during the last centuries took over the role of longer wetter phases in the earlier part of the Holocene.

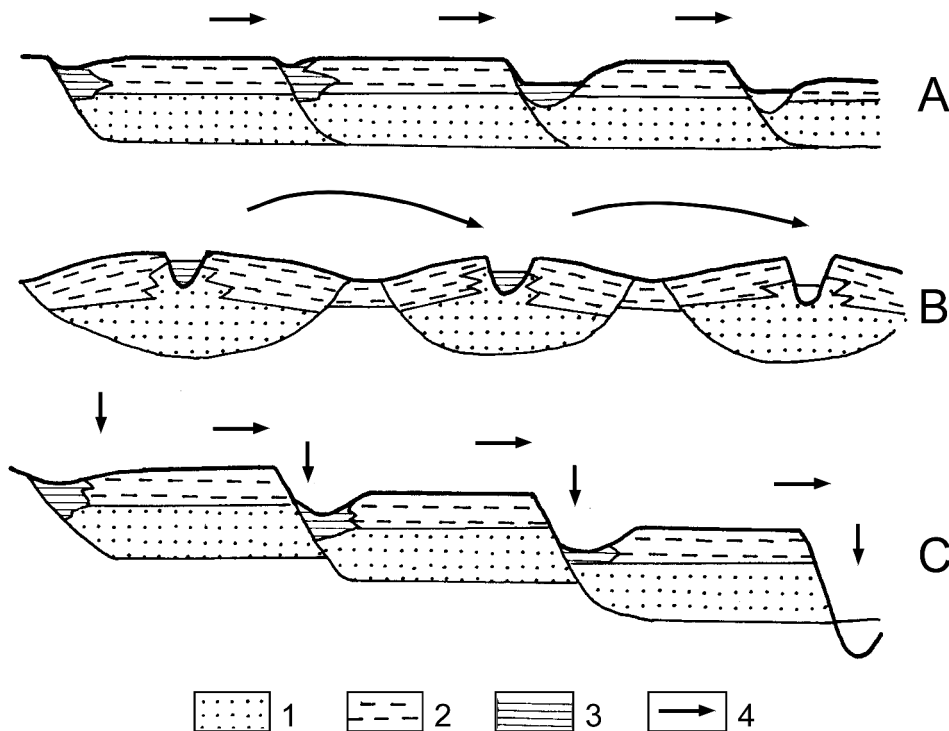

Fig. 6. Effects of cluster or phase on cut and fill system in evolution of alluvial plain: A: lateral shift; B: avulsion; C: cut and fill with incision. 1 – channel facies; 2 – overbank facies; 3 – paleochannel facies; 4 – direction of evolution.

REFERENCES

- Becker B. 1982. Dendrochronologie und Paläoökologie subfossiler Baumstämme aus Flussablagerungen, ein Beitrag zur nacheiszeitlichen Auenentwicklung im südlichen Mitteleuropa. *Mitteilungen der Kommission für Quartärforschung*, Österreichische Akademie der Wissenschaften, 5, Wien, 120 pp.
- Benito G., Machado M.J., Perez-Gonzales A. 1996. Climate change and flood sensitivity in Spain. In Branson J., Brown A.G., Gregory K.J. (eds), *Global Continental Changes, the Context of Palaeohydrology*, Geological Society Special Publ. 115, London 85–98.
- Bielański A.K. 1984. Records of flood history in upper Vistula basin (original: Materiały do historii powodzi w dorzeczu Górnej Wisły). In Fischer J. (ed), *Politechnika Krakowska*, Kraków, 12 p. (in Polish)
- Bond G., Showers W., Cheseby M., Lotti R., Almasi P., De Menocali P., Priore P., Cullen H., Hajdas J., Bonani G. 1997. A pervasive millennial – scale cycle in North Atlantic Holocene and glacial climates. *Science* 278, 1257–66.
- Brazdil R., Glaser R., Pfister Ch., Dobrovolny P., Antoine J.M., Barriendos M., Camuffo D., Deutsch M., Enzi S., Guidoboni E., Kozyta O., Rodrigo F.S. 1999. Flood events of selected European rivers in the sixteenth century. *Climatic Change* 43, 239–285.
- Bryson R.U., Bryson R.A. 1998. Application of a global volcanicity time-series on high-resolution paleoclimatic modelling of the Eastern Mediterranean. In Issar A.S., Brown N. (eds), *Water, Environment and Society in Times of Climatic Change*, Kluwer, Dordrecht, 1–19.
- Burkham D.E. 1972. Channel changes of the Gila River in Safford Valley, Arizona, 1846–1970. *Geological Survey Water-Supply Papers (US)* 655-G, 1–24.
- Camuffo D., Enzi S. 1995. Climatic features during the Spörer and Maunder Minima. In *Solar output and climatic during the Holocene*, *Paläoklimaforschung* 16, 105–124.
- Czyżowska E. 1997. Flood events at Boreal – Atlantic transition in sediments of Podgrodzie alluvial fan. *Dokumentacja Geograficzna IGiPZ PAN*, 5 (in Polish with English summary).
- Decamps H., Fortune M., Gazelle F. 1989. Historical changes of the Garonne river, southern France. In Petts G.E., Möller H., Roux A.L. (eds), *Historical changes of large alluvial rivers: western Europe*, J. Wiley, 249–268.
- Enzel Y., Ely L.L., House P.K., Baker V.R. 1996. Magnitude and frequency of Holocene palaeofloods in the southwestern United States: A review and discussion of implication. In Branson J., Brown A.G., Gregory K.J. (eds), *Global Continental Changes: The Context of Palaeohydrology*, Geological Society Special Publ. 115, 121–137.
- Froehlich W., 1998. Sediment load and channel erosion of Beskidian creeks during flood in July 1997 (original: Transport rumowiska i erozja koryt potoków beskidzkich podczas powodzi w lipcu 1997 roku). In Starkel L., Grela J. (eds), *Powódź w dorzeczu górnej Wisły w lipcu 1997 r.,. Konf. Naukowa*, Oddział PAN Kraków, 133–144 (in Polish).
- Frumkin A., Greenbaum N., Schick A.P. 1998. Paleohydrology of the Northern Negev: comparative evaluation of two catchments. In Issar A.S., Brown N. (eds), *Water, Environment and Society in times of climatic change*, Kluwer, 97–111.
- Goswami D.C. 1988. Fluvial regime and flood hydrology of the Brahmaputra river, Assam. *Memoir Geological Society in India* 41, 53–75.
- Kotarba A. 1995. Rapid mass wasting over last 500 years in the High Tatra Mountains. *Questiones Geographicae, Special Issue* 4, 177–183.
- Krapiec M. 1992. Late Holocene treering chronologies of South and Central Poland. *Geologia* 18, 3, Wyd. AGH, Kraków, 37–119 (in Polish with English summary).
- Krapiec M. 1998. Oak dendrochronology of the Neoholocene in Poland. *Folia Quaternaria* 69, 5–134.
- Leuschner H.H., Spurk M., Baillie M., Jansma E. 2000. Stand dynamics of prehistoric oak forest derived from dendrochronologically dated subfossil trunks from bogs and riverine sediments in Europe. *Geolines* 11, Prague, 118–120.
- Lopez-Aviles A., Ashworth P.J., Macklin M.G. 1998. Floods and Quaternary sedimentation style in a bedrock controlled reach of the Bergantes river, Ebro basin, Northeast Spain. In Benito G., Baker V.R., Gregory K.J. (eds), *Palaeohydrology and Environmental Change*, J. Wiley, 181–198.
- Lvovitch M.I. 1979. World water resources and their future (English translation by R.L.Nace). *American Geophysical Union*.
- Magny M. 1993. Holocene fluctuations of lake levels in the French Jura and sub-Alpine ranges and their implications for past general circulation pattern. *The Holocene* 3, 4, 306–313.
- Niedziałkowska E., Skubisz A., Starkel L. 1977. Lithology of the Eo- and Mesoholocene alluvia in Podgrodzie upon Wisłoka river. *Studia Geomorphologica Carpatho-Balcanica* 11, 89–100.
- Patzelt G. 1977. Der zeitliche Ablauf und das Ausmass postglazialer Klimaschwankungen in den Alpen. In Frenzel B. (ed.), *Dendrochronologie und postglaziale Klimaschwankungen in Tirol, Veröffentlichungen des Museum Ferdinandeum* 67, 93–123.
- Pavese M., Banzon V., Colacino M., Gregori G.P., Pasqua M. 1992. Three historical data series on floods and anomalous climatic events in Italy. In Bradley R.S., Jones P.O. (eds), *Climate since AD 1500*, Routledge, 155–170.
- Probst J.L. 1989. Hydroclimatic fluctuations of some European rivers since 1800. In Petts G.E., Möller H., Roux A.L. (eds), *Historical change of large alluvial rivers: Western Europe*, J. Wiley, 41–56.
- Rączkowski W., Mrozek T. 2002. Activating of landsliding in the Polish Flysch Carpathians by the end of 20-th century. *Studia Geomorphologica Carpatho-Balcanica* 36, 91–101.
- Rumsby B.T., Macklin, M.G. 1996. River response to the last neoglacial (The Little Ice Age) in northern, western and central Europe. In Branson J., Brown A.G., Gregory K.J. (eds), *Global Continental Changes: The context of Palaeohydrology*, Geological Society Special Publ. 115, London, 217–233.
- Soja R. 1977. Deepening of channel in the light of the cross profile analysis. *Studia Geomorphologica Carpatho-Balcanica* 11, 127–138.
- Starkel L. 1976. The role of extreme (catastrophic) meteorological events in contemporary evolution of slopes. In Derbyshire E. (ed.), *Geomorphology and Climate*, J. Wiley, Chichester, 203–246.
- Starkel L. 1983. The refectation of hydrological change in the fluvial environment of the temperate zone during the last 15 000 years. In Gregory K.J. (ed.) *Background to Palaeohydrology*, J. Wiley, 213–237.
- Starkel L. 1998. Frequency of extreme hydroclimatically – induced events a key to understanding environmental changes in the Holocene. In Issar A.S., Brown N. (eds), *Water, Environment and Society in Times of Climatic Changes*, Kluwer Publ., 273–288.
- Starkel L. 1999a. 8500–8000 yrs BP humid phase – global or regional? *Science Reports of Tohoku University, 7-th Series, Geography* 49, 2, 105–133.
- Starkel L. 1999b. Space and time scales in geomorphology. *Zeitschrift für Geomorphologie, Suppl.-Bd* 115, 19–33.
- Starkel L. 2001. Extreme rainfalls and river floods in Europe during the last millennium. *Geographia Polonica* 742, 69–79.

- Starkel L. 2002. Change in the frequency of extreme events as the indicator of climatic change in the Holocene (in fluvial systems). *Quaternary International* 91, 25–32.
- Starkel L. 2003. Short-term hydrological changes. In Gregory K.J., Benito G. (eds), *Palaeohydrology, understanding Global Change*, J. Wiley, 20, 337–356.
- Starkel L. (ed.) 1997. Role of heavy downpours in the relief transformation of Miechow Upland – with example of 15 September 1995 event. *Dokumentacja Geograficzna IG PAN* 8, Warszawa, 108 pp. (in Polish with English summary)
- Starkel L., Basu S. (eds) 2000. Rains, landslides and floods in the Darjeeling Himalaya. Indian National Science Academy, New Delhi, 168 pp.
- Starkel L., Kalicki T., Krąpiec M., Soja R., Gębica P., Czyżowska E. 1996. Hydrological changes of valley floors in the upper Vistula basin during Late Glacial and Holocene. *Geographical Studies, Special Issue* 9, Warszawa, 7–128.
- Starkel L., Sarkar S. 2002. Different frequency of threshold rainfalls transforming the margin of Sikkimese and Bhutanese Himalayas. *Studia Geomorphologica Carpatho-Balcanica* 36, 51–67.
- Starkel L., Singh S., Soja R., Froehlich W., Syiemlich H., Prokop P. 2002. Rainfalls, runoff and soil erosion in the extremely humid area around Cherrapunji, India (preliminary observations). *Geographia Polonica* 75, 1, 43–65.
- Stuiver M., Braziunas T.F., Becker B., Kromer B. 1991. Climatic Solar, Oceanic and Geomagnetic influences on Late-Glacial and Holocene atmospheric $^{14}\text{C}/^{12}\text{C}$ change. *Quaternary Research* 35, 1–24.
- Ziętara T. 1968. Role of heavy rains and floods in the modelling of Beskid relief. *Prace Geograficzne IG PAN*, 60, 1–116 (in Polish with English summary).